

LPA Series

Premium LED Flat Panel



DESCRIPTION

Trace-Lite's LPA22 and LPA24 Advantage Series of backlit LED panels offers incredible performance in an energy-efficient, slim profile package. Ideal for office spaces, schools, hospitals and any indoor location that requires even illumination and lower maintenance. The LPA Series is compatible with most standard T-bar grid ceilings and includes 0-10V dimming standard. Trace-Lite LED panels offer soft and uniform light with PMMA optical lensing that will not yellow over time. All panels are packaged in a quantity of four.

SPECIFICATIONS

Construction:

- Precision die-formed aluminum enclosure in a white finish with seamless corners
- Recessed design fits most standard T-bar grid ceilings
- Backlit design, LEDs sit at the back of the enclosure aimed directly at the diffuser to evenly illuminate the entire surface of the panel
- Sturdy frame prevents warping due to the slightly more elevated profile

Optics/LEDs:

- UV-stabilized PMMA optical lenses over the LEDs that will not yellow over time
- Soft and uniform light distribution, 120° beam
- Efficacies up to 133 LPW to maximize energy savings and utility rebates
- Available in 3000K, 3500K, 4000K and 5000K CCT
- CRI ≥80
- L70 @ 54,000 hrs

Electrical:

- 120-277VAC, 50/60Hz
- 0-10V Dimming driver
- Power supply with high power factor of 90% typical

Testing & Compliance:

- cETL Listed, rated for insulated ceilings (IC Rated)
- Meets IP20 rating, Damp Location
- DesignLights Consortium® (DLC) PREMIUM Qualified
- Operating temperatures: -10°C to 40°C (14°F to 40°C)

Installation:

- Unit simply lifts through grid ceiling and rests on T-bars
- Easy installation in new construction or retrofit
- Standard recessed mounting in most 2' x 2' or 2' x 4' grid ceilings
- Earthquake clips included

Accessories:

- Optional surface mount kit (LP22-SMK, LP24-SMK)
- Suspension mount kit (LP-CMK)
- Field-installable battery packs available for emergency egress lighting ([LBD Series](#))

Warranty:

- Five Year Warranty (Terms and Conditions Apply)

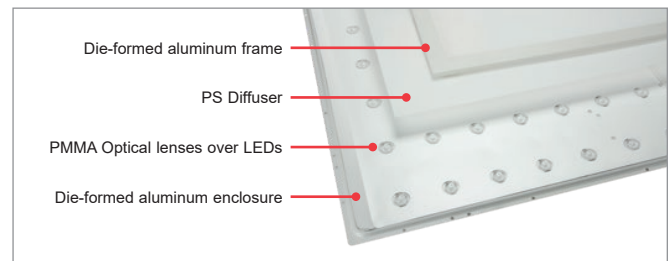
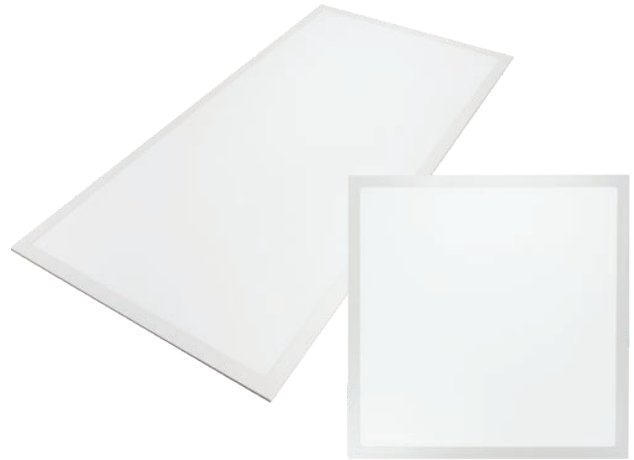

Backlit design for even illumination

Specs at a Glance					* Nominal Wattage			
Configuration	LPA22 (2' x 2')				LPA24 (2' x 4')			
Wattage (W)*	30W				40W			
CCT (K)	3000K	3500K	4000K	5000K	3000K	3500K	4000K	5000K
Lumens (lm)	3736	3776	3815	3933	4994	5035	5076	5200
Efficacy (LPW)	127	128	130	133	125	125	127	129
CRI	>80							
Input Voltage	120-277VAC, 50/60Hz, 0-10V Dimmable							
Operating Temp	-10°C to 40°C (14°F to 104°F)							
Certifications	cETL Listed, IC Rated, DLC PREMIUM							
Warranty	5 Years							
Weight	5.7 lbs				10.9 lbs			

Model: _____ Date: _____

Accessories: _____

Job Name: _____ Type: _____

Ordering Information (Example: LPA22-30-5K)

Series/Wattage	CCT	Accessories ² (Field Installed)
LPA22-30 ¹ = 2' x 2', 30W	3K = 3000K	LBD-5-NC-CW-C ^{3,4} = 5 Watt Battery Pack for Emergency Egress
LPA24-40 ¹ = 2' x 4', 40W	35K = 3500K	LBD-7-NC-CW-C ^{3,4} = 7 Watt Battery Pack for Emergency Egress
	4K = 4000K	LBD-10-NC-CW-C ^{3,4} = 10 Watt Battery Pack for Emergency Egress
	5K = 5000K	LBD-13-NC-CW-C ^{3,4} = 13 Watt Battery Pack for Emergency Egress
		LBD-17-NC-CW-C ^{3,4} = 17 Watt Battery Pack for Emergency Egress
Notes		LP-CMK = Cable Mount Kit
¹ All panels are packaged in quantity of four (4pcs/carton)		LP22-SMK ⁵ = 2' x 2' Surface Mount Kit
² Order as a separate line item. Shipped in a separate box for final installation in the field		LP24-SMK ⁵ = 2' x 4' Surface Mount Kit
³ See back page for battery pack lumen output. Not compatible with LPxx-SMK kit		
⁴ Consult LBD spec sheet for more details on battery pack		
⁵ Not recommended for textured ceilings		

Dimensions

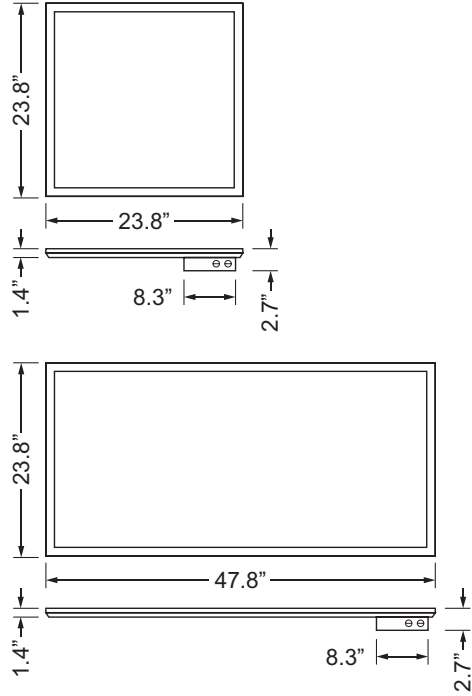

Sample Photometry

LPA22-30-4K

IES: TYPE VS Very Short

MOUNTING HEIGHT: 10'

TILT: ZERO

HORIZONTAL SPACING CRITERIA: 1.28

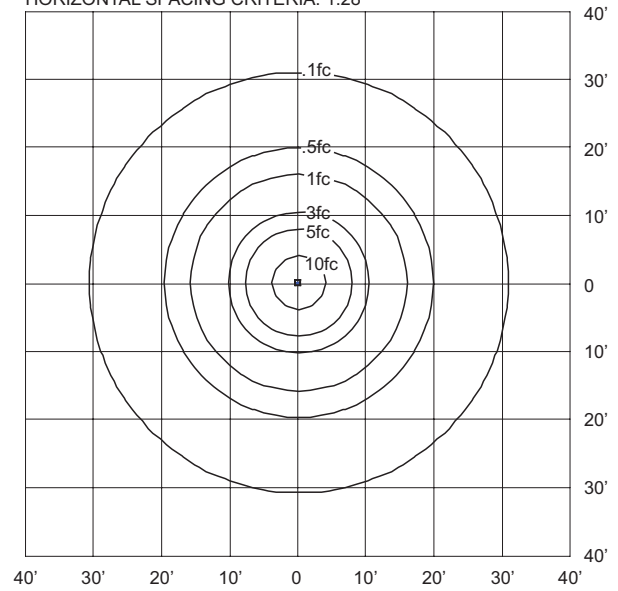

Cable Mount Kit (LP-CMK)

Optional cable mounting kit (LP-CMK) allows for suspended installations from any ceiling type.

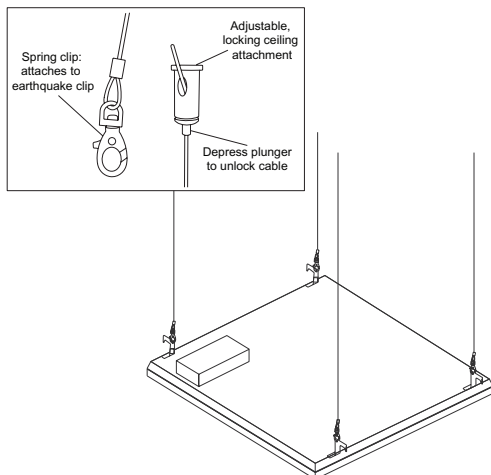

Surface Mount Kit (LPXX-SMK)

Optional surface mount kit (LP22-SMK/LP24-SMK) allows for installation on plaster or other hard ceilings.

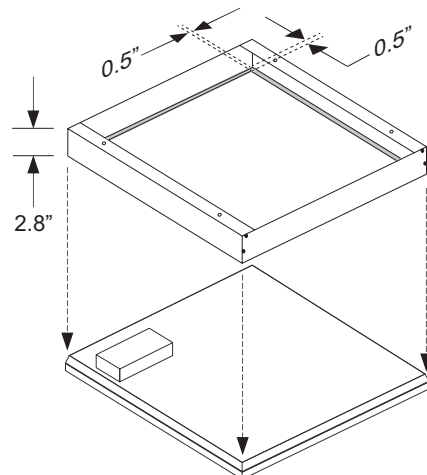

Lumen Output Summary for LBD Battery Pack Accessories (Consult LBD spec sheet for more details. [Click Here](#))

LPA Panel Battery Packs:			LBD-5-NC-CW-C	LBD-7-NC-CW-C	LBD-10-NC-CW-C	LBD-13-NC-CW-C	LBD-17-NC-CW-C
<i>Model</i>	<i>Lumens</i>	<i>Wattage</i>	<i>Battery Backup Lumens</i>				
LPA22-30-3K	3736	30	552	773	1104	1436	1878
LPA22-30-35K	3776	30	556	779	1113	1447	1893
LPA22-30-4K	3815	30	565	791	1131	1470	1922
LPA22-30-5K	3933	30	578	809	1157	1504	1967
LPA24-40-3K	4994	40	543	761	1087	1413	1848
LPA24-40-35K	5035	40	543	761	1087	1413	1848
LPA24-40-4K	5076	40	548	767	1096	1425	1863
LPA24-40-5K	5200	40	561	785	1122	1458	1907